

Installation and User Guide

Commander VoIP Telephone

1114 model with Headset socket

IMPORTANT

**THIS PRODUCT MUST BE CONFIGURED PRIOR
TO INSTALLATION**

PLEASE READ THIS GUIDE FIRST

GAI-TRONICS

A Division of Hubbell Ltd

CONTENTS

| | | |
|-----|--|----|
| 1 | Safety Information | 2 |
| 2 | Product Description | 3 |
| 3 | Features | 4 |
| 4 | Installation | 5 |
| 4.1 | Sequence of Events | 5 |
| 4.2 | Pre-installation..... | 5 |
| 4.3 | Dimensions..... | 8 |
| 4.4 | Preparation..... | 8 |
| 4.5 | Mounting Methods..... | 10 |
| 4.6 | Connections and Cabling | 13 |
| 4.7 | Option Settings, Configuration and Programming | 18 |
| 4.8 | Assembly of Telephone on to Installed Base | 18 |
| 5 | Operation..... | 20 |
| 5.1 | Making and Receiving Calls..... | 20 |
| 5.2 | Last Number Redial..... | 21 |
| 5.3 | Recall Function..... | 21 |
| 5.4 | Secrecy or Mute Function | 21 |
| 5.5 | Headset Operation | 22 |
| 6 | Maintenance | 23 |
| 6.1 | Procedures | 23 |
| 6.2 | Fault Finding & Field Repairs | 23 |
| 6.3 | Possible Operating Faults | 24 |
| 7 | Technical Specifications | 24 |
| 7.1 | Suitability for Use | 24 |
| 7.2 | Product Features | 25 |
| 7.3 | Headset | 26 |
| 7.4 | Physical Characteristics | 26 |
| 7.5 | Environmental Considerations | 27 |
| 7.6 | Related Standards and Regulations | 27 |
| 7.7 | Recycling Information..... | 28 |
| 8 | CE Declaration | 29 |
| 9 | Licensing Notices | 29 |

1 Safety Information

- ▲ **IMPORTANT:**
ALL POSSIBLE MEASURES MUST BE TAKEN TO ENSURE WATER, FLUID OR DUST DOES NOT CONTAMINATE THE INTERNAL COMPONENTS OF THIS TELEPHONE WHILST UNPACKING, PREPARING OR INSTALLING IT, OR BY NEGLIGENCE.
FAILURE TO OBSERVE THIS PRECAUTION WILL INVALIDATE YOUR WARRANTY
- ▲ **Please read these instructions thoroughly before starting installation. These products must be installed by competent personnel familiar with electrical and network installations.**
- ▲ **This product can contain hazardous voltages (if connected to the isolated output contacts. If in doubt always isolate power supplies to the unit before opening the case.**
- ▲ **This product must be configured prior to installation. See section 4.2.1 for details**
- ▲ **Some versions of this product are supplied with long handset or headset cables, which could present a trip hazard.** Therefore care must be taken when using the handset/headset at extended distances, so that personnel or equipment in the vicinity are not impeded, trapped or entangled by the cord. Also, care must be taken to stow these long cord handset/headsets so they do not pose an entanglement or tripping hazard.
- ▲ **Noise level hazard.** The telephone ringer can develop a sound level in excess of 90dBA @ 1 metre. Therefore, it is the installer's responsibility to take the necessary measure to comply with the European directive 2003/10/EC regarding the exposure of workers to the risks arising from physical agents (noise).

2 Product Description

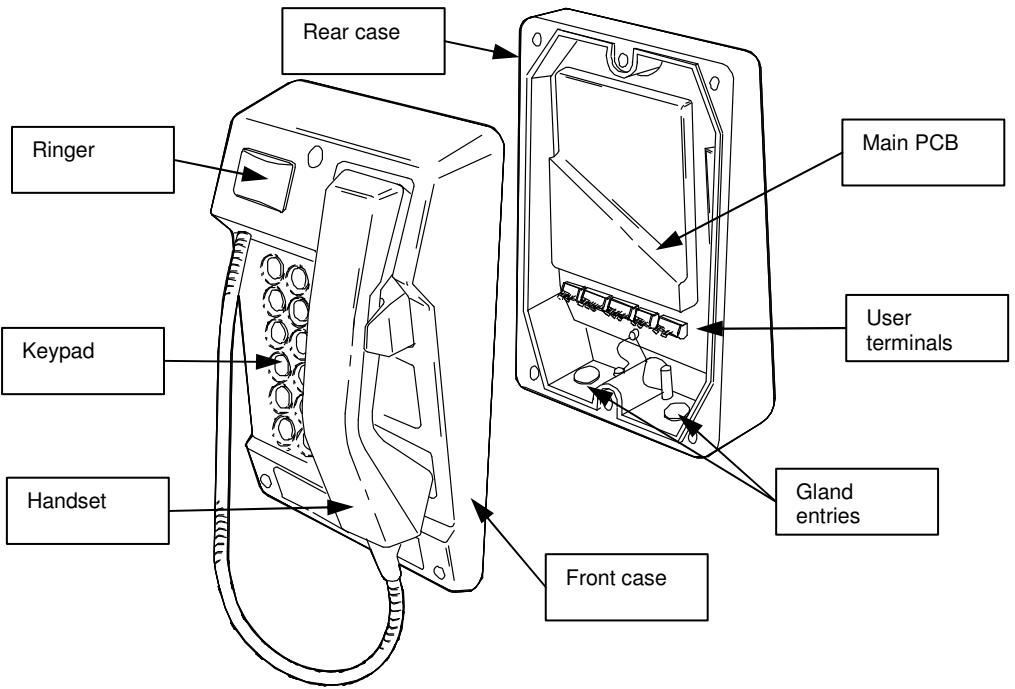

Commander 1114 VoIP Telephone at a glance

3 Features

This manual describes the Commander 1114 voice over internet protocol (VoIP) telephone. Commander 1114 is a rugged telephone built to withstand arduous use and environmental extremes. Features include:

- Glass filled polyester body - rugged and corrosion free.
- Weather resistant up to IP66
- Rugged handset with curly cord or armoured stainless steel cord.
- Hearing aid compatible inductive coupling as standard
- Headset option available.
- Integral 90dBA ringer with volume adjustment.
- Programmable, volt-free contact output
- Available in various button configurations including zero button (hotdial) versions
- One touch dial memories (1, 3, 6 and 18 button versions only)
- SIP compatible (RFC3261)
- Automatic outgoing call diversion (memory list)
- Real-time alarm reporting via email or Syslog
- Power over Ethernet 802.3af compatible (spare pair only)
- Configurable via web page or download

4 Installation

Please read all these instructions thoroughly before starting installation.

THESE UNITS MUST BE CONFIGURED BEFORE THEY ARE INSTALLED.

All GAI-Tronics VoIP telephones have identical settings as factory defaults, so each one must be individually configured to give it a unique identity on the network. This may be difficult to do after the units are installed.

4.1 Sequence of Events

In order to ensure the installation is as trouble free as possible, please follow the recommended sequence of events described in detail in the sections below. In summary this sequence is:

- Pre installation – preparations to make before installation, including initial configuration.
- Mounting – physically fixing the unit in place
- Connection – attach cables
- Testing – ensure it functions as expected
- Put into service – finalise the installation

4.2 Pre-installation

Please ensure that each unit is configured prior to installation, and that the requirements listed below are taken into consideration before installation begins:

4.2.1 Initial Configuration

As factory default, each Commander 1114 has the following settings:

- Static IP address **192.168.1.2**
 - Log in user name: **user**
 - Log in password: **password**
-

As an absolute minimum, you will need to either assign a unique static IP address to each unit or set it to DHCP.

IMPORTANT: After changing the IP address of the telephone you will need to browse to the new IP address to access the configuration, instead of the default 192.168.1.2.

IMPORTANT: If DHCP is enabled, ensure that there is a suitable DHCP server available on the network and that you have a

means by which to discover the IP address of the telephone allocated by the DHCP server. There is no other way to access a DHCP enabled VoIP telephone over the network without being able to find the IP address allocated by the DHCP server.

If using DHCP please note that each unit already has a unique host name (factory set to the unit's serial number).

To make these changes, log in to the phone's web pages using the details above.

You will need to power the unit (using DC power or PoE) and to connect it to a network. See section 4.6.2.

You will also need the Configuration guide, available from:

www.gai-tronics.org/support/voip-support/

Note there is also a link to this support page on the phone's home page. The configuration guide explains all the configuration settings in detail.

IMPORTANT WARNING

Please ensure when changing the IP address, user name or password, that the new details are recorded and securely kept. If these details are lost it will not be possible to access the unit's configuration web pages. If this occurs the unit will need to be returned to factory for reset.

4.2.2 Requirements before installation

Before installing the unit, please ensure that the following are available:

- **Pre configuration.** It is essential that each phone is pre-configured before installation, see section 4.2.1 above.
- **Power.** Ensure that there is a suitable means of providing power to the phone, either a DC supply or PoE. See section .
- **Ethernet.** The phone must be connected to a 10/100BaseT Ethernet network via CAT5 STP cable, no further than 95m from the network switch. See section for connections
- **Earth.** The unit must be connected to the equipotential bonding system for the whole area in which the intrinsically safe equipment is being used. See section 4.6.3 for details.
- **Glands.** Glands are not supplied. All glands and cables should comply with IP54 or better. Note that the environmental rating

of the telephone will not exceed that of the glands, i.e. in order to maintain an IP66 rating, glands must also meet IP66.

4.2.3 Cable entries

Commander 1114 has 2 M20 cable entry gland positions, but potentially 4 different connections could be made to it:

- Ethernet (always)
- Earth (always)
- Power (if not PoE)
- External relay signal (if required)

Before installing, give consideration to the options available and review the alternative connection schemes in section 4.6.5 to ensure that the required connections can be made using the available glands. For example Power over Ethernet (PoE) is the recommended method of providing power, to avoid the need for a separate power cable.

If a high voltage is connected to the relay contacts (for example to activate a mains-powered beacon) then that cable **must** be segregated from all other cables and routed through its own gland.

Upon installation care should be taken to ensure that incoming cables are cleanly routed with a view to maintaining segregation from the telephone's internal wiring (i.e. handset, hookswitch, ringer and headset if fitted).

4.3 Dimensions

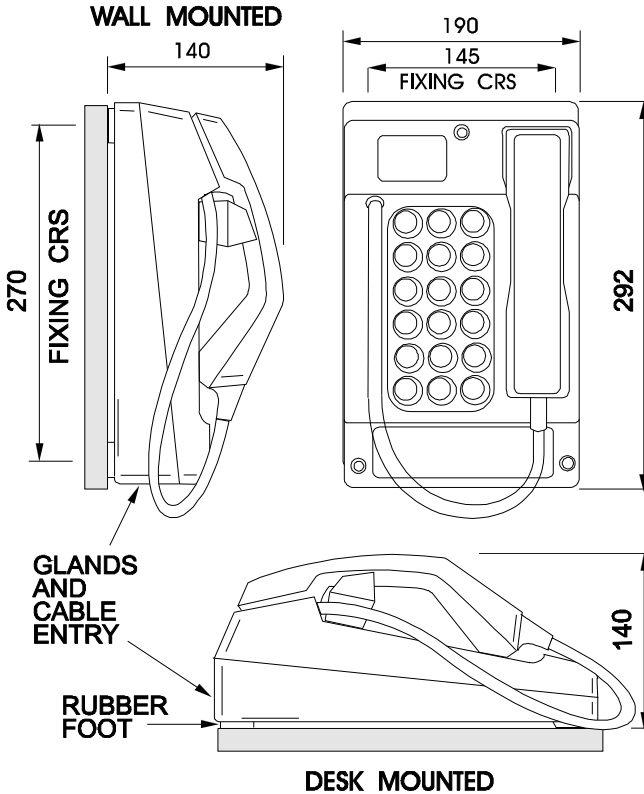

Four 7mm-clearance holes in the Rear Casing (outside the environmental seal) allow it to be screwed or bolted to a wall, or to a pole-side mounting kit (part no 100-02-0208-001).

The holes are arranged in a rectangle, as follows -

- Horizontal separation between centres: 145.0mm
- Vertical separation between centres: 270.0mm. The lower pair are about 10mm up from the bottom edge of the unit.

Handset cord lengths:

Standard curled cord: 320mm extending to 1m.

Standard stainless steel cord: 755mm

Other cord lengths are available as special options: contact GAI-Tronics for details.

4.4 Preparation

ALL POSSIBLE MEASURES MUST BE TAKEN TO ENSURE WATER, FLUID OR DUST DOES NOT CONTAMINATE THE INTERNAL COMPONENTS OF THE TELEPHONE WHILST UNPACKING, PREPARING AND INSTALLING IT IN INCLEMENT WEATHER CONDITIONS OR BY NEGLIGENCE.

FAILURE TO TAKE THIS PRECAUTION WILL INVALIDATE YOUR WARRANTY

The telephone body must **NOT** be opened, nor glands removed or cables disconnected unless all supplies to the telephone, including network cables, power cables and external devices have been first isolated elsewhere.

If only one gland entry is used, the sealing plug fitted to the second gland position should be left in place.

1. Place the telephone on its base on a firm horizontal surface.
2. Using a 5mm Allen key, release the Front Casing from the Rear Casing. The screws are captive in the Front Casing.
3. Noting the positions, disconnect the keypad cable at the keypad. See diagram in section 4.8
4. Disconnect the ringer cable from header HD1 in the rear section, see diagram in section 4.8
5. Take care when removing the Front Casing from the Rear Casing and storing the Front Casing not to damage the internal electronics, specifically the headset switch terminals or connector PCB if fitted.
6. Remove the RED blanking plug from the cable entry hole leaving the BLACK blanking plug in situ.
7. Select the appropriate size gland for the cable used.
8. Take care when inserting the selected gland into the threaded cable entry hole. Follow the gland manufacturer's instructions particularly with respect to sealing, installation and earthing.
9. After the glands have been fitted select the required mounting method and follow the appropriate instructions below.

4.5 Mounting Methods

4.5.1 Wall Mounting

To ensure weatherproof integrity when wall mounted, external cables should enter the enclosure from the bottom via the two 20mm gland entries provided.

IMPORTANT WARNING:

DO NOT DRILL ANY EXTRA HOLES AS THIS WILL INVALIDATE YOUR WARRANTY.

1. Remove rubber feet from the Rear Casing if fitted. Ensuring that the cable entries are at the bottom offer the Rear Casing up to the vertical surface and mark through the fixing holes.
Do not use the Rear Casing as a template to drill the holes. Work only from the marked positions.
2. Drill the holes in the vertical surface to suit the best method of fixing.
3. Ensure the Rear Casing is securely attached to the vertical surface using the four 7mm diameter screw holes provided. No sealing washers are necessary.

IMPORTANT: Do not use countersunk headed fixing screws. Only use round head, socket cap head or pan head screws. Take care not to over tighten the screws as doing so may damage the case and will invalidate your warranty.

4. Pass the cable through the gland and tighten, following the gland manufacturer's instructions.
5. Continue the installation procedure with the connection of individual wires from the cable as described under sections 4.6 onwards.

4.5.2 Pole-side Mounting

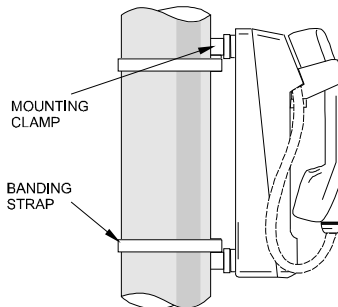

Kit No 100-02-0208-001

This accessory kit is for mounting GAI-Tronics telephones on to the side of round poles of 100mm to 200mm diameter, or on to square or rectangular section uprights of 100mm to 150mm across the mounting surface. For flat mounting on surfaces greater than 150mm across use the desk or wall mounted methods as appropriate.

Figure 1 – Pole side mounting

NOTE:

Banding straps (large scale worm-drive clamps) are not included in this kit and must be obtained separately. For details of where mounting kits can be obtained, refer to GAI-Tronics .

1. Remove rubber feet from the Rear Casing if fitted. Attach the pole mounting clamp assemblies to the Rear Casing using the M6 x 25 screws provided.
2. Ensuring that the glands are at the bottom, pass a proprietary banding strap round each of the pole mounting clamps and the support pole. Tighten securely.
3. Continue the installation procedure with the connection of individual wires from the cable as described under sections 4.6 onwards.
4. Secure the telephone Front Casing to the Rear Casing.
5. Re-tighten the straps firmly and trim off any excess band material. For security the driving head of the band may also be sawn off.

4.5.3 Desk Mounting / Rake

IMPORTANT WARNING:- Risk of impact or falling

This telephone, when used in a desk mounting mode, should be located on a horizontal, flat non-slip surface. Due to the heavy and robust construction of the unit, users must take care when using the handset or headset, not to pull the cord to such an extent as to cause the telephone to be pulled off the flat surface, and possibly cause damage or injury to persons or equipment. Therefore it is recommended that the unit be fixed in position using fixing positions and method detailed in section 4.5 if there is any risk of the unit being dislodged as described above.

To provide a 'rake' for convenient operation, the Front Casing may be turned through 180° before it is fitted to the Rear Casing. Thus the cable entries are at the rear of the telephone.

1. Ensure that the supplied rubber feet are fitted to the underside of the Rear Casing if the telephone is not fixed into position.
2. Rotate the Front Casing through 180° and fold the keypad ribbon cable to ensure that it lays flat against the potted block when re-assembled. Refer to Ribbon cable positions (page 19)

3. Continue the installation procedure with the connection of individual wires from the cable as described in sections 4.6 onwards.

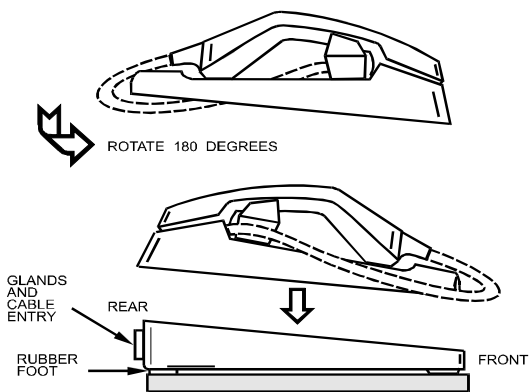

Providing the rake

4.6 Connections and Cabling

IMPORTANT WARNING:-

ISOLATE ANY HIGH VOLTAGE CONNECTIONS TO THE OUTPUT CONTACTS ELSEWHERE BEFORE OPENING THE CASE.

ALL TERMINALS MUST BE CONNECTED IN ACCORDANCE WITH THIS INSTALLATION GUIDE. ANY DEVIATION FROM THIS MAY RESULT IN AN UNSAFE INSTALLATION.

Make the following connections to the unit:

- Ethernet (including shield connection to STP cable)
- Power (either PoE or separate dc supply)
- Earth (to the system equipotentially bonded earth point)
- External relay (if required)

Details of each connection are given below. There are a number of possible cabling schemes illustrated at the end of the section

4.6.1 Ethernet connections

The Ethernet port is provided on 8 spring terminals on connectors CON2, CON3 and CON4 as follows:

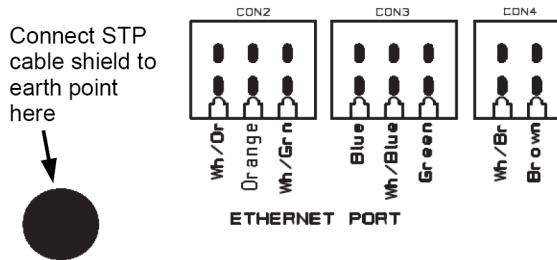

Connect the standard colour-coded cables to the terminals as shown.

Note that the Ethernet cable must be CAT-5 or equivalent STP (shielded twisted pair) and that the shield must be terminated to the earth point as shown.

Note: the Ethernet cable termination is to TIA/EIA-568 T568B

4.6.2 Power connections

Power can be provided either:

- Via Power-over-Ethernet (PoE), IEEE 802.3af.

NOTE: PoE can only be provided on spare pair (Alternative

B), not data pair. Ensure that your PoE switch or injector can provided PoE by this method.

Or

- Isolated DC supply on CON 6:
24 – 48Vdc nominal (the limits are 22-53Vdc)
250mA

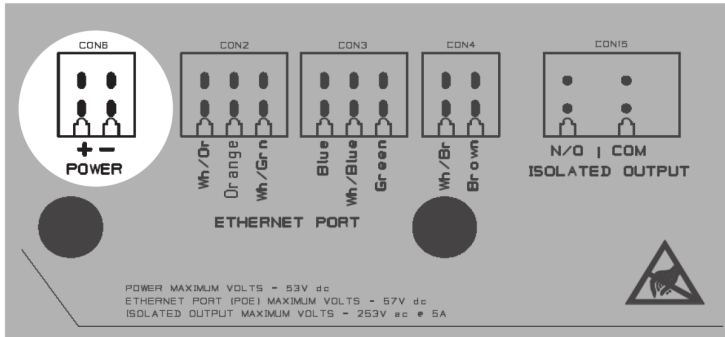

4.6.3 Earth connection

The Commander 1114 has an earth point which needs to be connected to the equipotential bonding system for the whole area in which the equipment is being used, using one of the following:

1. At least two separate conductors each with a copper cross sectional area of 1.5mm^2 (minimum).

Or

2. At least one conductor with a copper cross sectional area of 4mm^2 (minimum).

The earth point is connected to 2 earth studs on the case – one available externally and one internally.

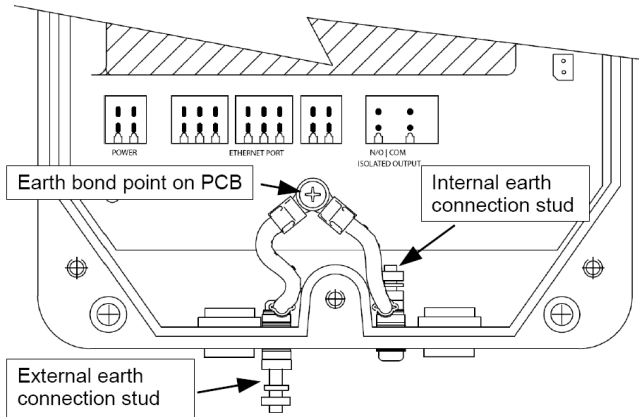

4.6.4 External relay connections

Commander 1114 is equipped with a single, normally open relay contact on CON15:

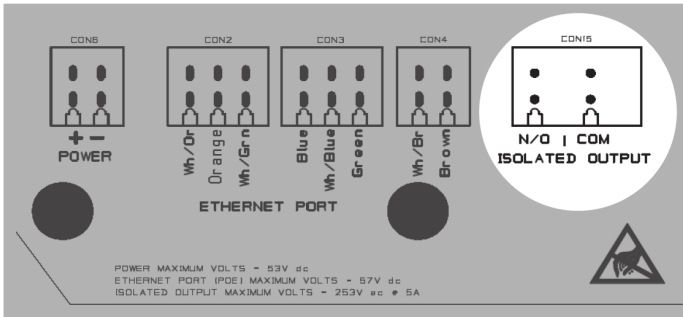

This contact is programmable via the unit's web pages to give a variety of different functions, such as activation on ringing, or off-hook, etc. Refer to the configuration guide for full details (available from www.gai-tronics.org/support/voip-support/)

CONTACT RATING:

Maximum voltage = 253Vrms (nominal 230V)

Maximum current = 5A

Note: no fusing or transient protection is provided; this must be installed externally.

The relay fitted to the Commander 1114 has a continuous current rating of 5A. It has been brought to our attention that some beacons, whilst having a current rating well below this figure, actually generate

current spikes far in excess of this during making and breaking of the relay contacts. These current spikes can cause the relay contacts to fail.

GAI-Tronics have been working closely with Beacon manufacturer, to resolve this issue and our recommendations are:

- Restrict the use of beacons to non AC variants only or those with a maximum flash intensity of 5 joules.
- Where beacons with greater than 5 joule flash intensity are required, the beacons should be purchased direct from GAI-Tronics, who will carry out a free of charge modification to the beacon to ensure compatibility with the Commander 1114.

4.6.5 Alternative cabling schemes

Upon installation care should be taken to ensure that incoming cables are cleanly routed with a view to maintaining segregation from the telephone's internal wiring (i.e. handset, hookswitch, ringer and headset if fitted).

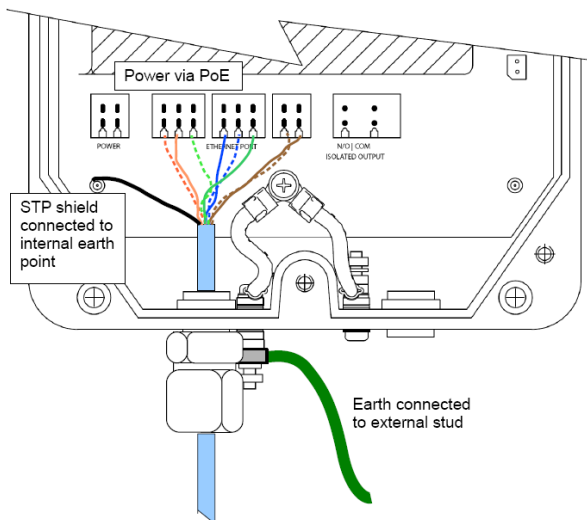

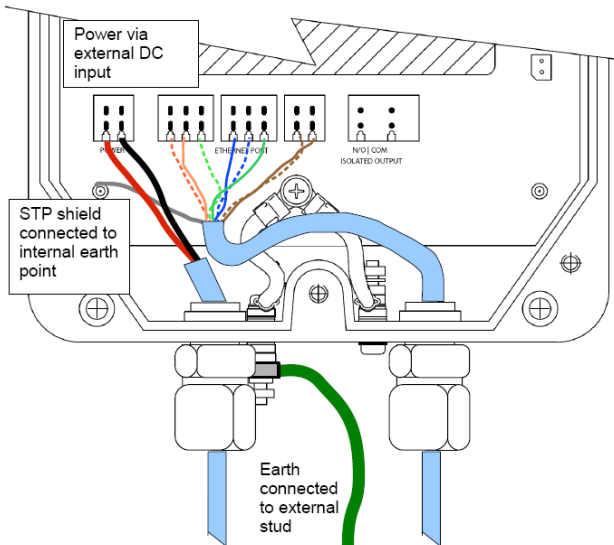
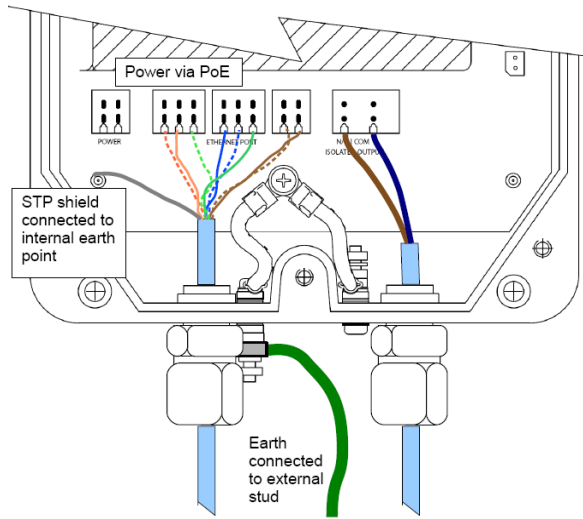

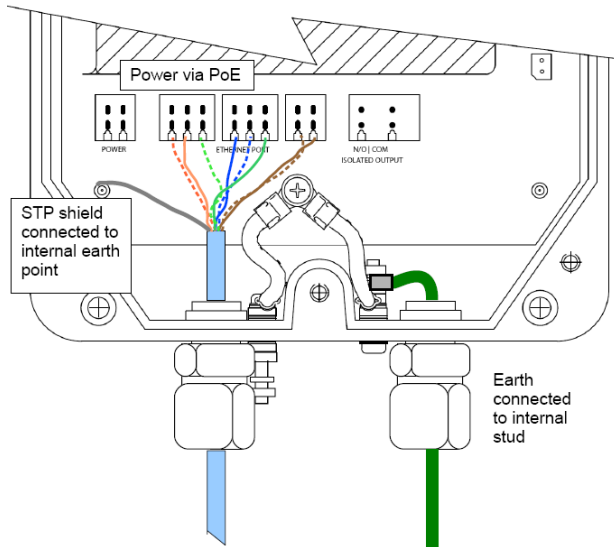

4.7 Option Settings, Configuration and Programming

Commander 1114 has no internal switches or jumpers. No option settings are made on the telephone itself. All option settings, configuration and programming is done remotely via the unit's web pages or by using a configuration file. Please refer to the separate configuration guide for full details, available from:

www.gai-tronics.org/support/voip-support/

Please note: the configuration guide covers all models of GAI-Tronics VoIP telephone. Specifically the Commander 1114 does not include the following features:

- External inputs
- LEDs
- Serial port
- Only a single relay (OUTPUT1) is fitted.

4.8 Assembly of Telephone on to Installed Base

1. Ensure that the keypad connection between the base and the keypad PCB is made observing the correct orientation of the connector. A keyway on the connector facilitates ensuring that the ribbon cable connector is correctly orientated. Do not forcibly fit the connectors

IMPORTANT – FAILURE TO ENSURE THE CORRECT ORIENTATION OF THE CONNECTOR COULD CAUSE DAMAGE TO THE TELEPHONE

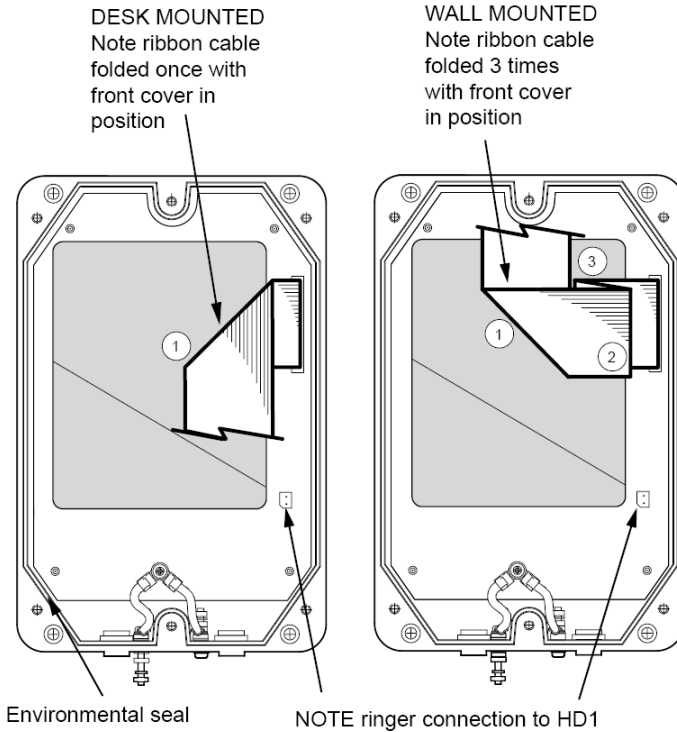

Ribbon cable positions

2. Ensure that the ringer connection is connected from the front case to HD1 on the main PCB in the rear case.
3. Offer the Front Casing to the Rear Casing, with the ribbon cable appropriately folded as shown in diagram above; ensure that the cable will not be trapped when the Front Casing is tightened down. Take care that all folds are made, the ribbon cable can lay flat and that the insulation can not become damaged. Check also that the environmental seal is in position.
4. Upon installation care should be taken to ensure that incoming cables are cleanly routed with a view to maintaining segregation from the telephone's internal wiring (i.e. handset, hookswitch, ringer and headset if fitted).
5. Tighten the three securing screws firmly.

5 Operation

Note that features may vary according to the model supplied, and that certain features are user-programmable. Please see the configuration guide for full details.

5.1 Making and Receiving Calls

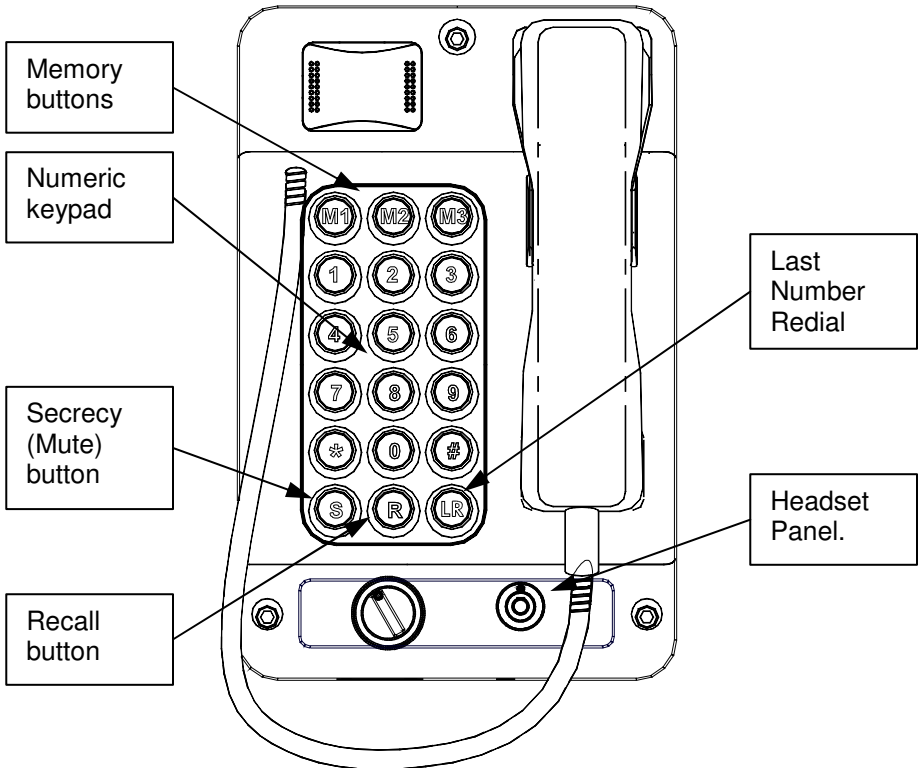

- To make a call, lift the handset, wait for dial tone, dial required digits (or press required memory button or Last Number Redial where fitted) and wait for connection.
- Memory buttons are associated with memory lists (on the [Dialling and Memories / Memory Lists](#) web page), ie M1 will trigger memory list 1, M2 memory list 2, etc.
- For hot-dial versions (i.e. no buttons fitted), the OFFHOOK memory list ([Dialling and Memories / Basic Info](#) web page) should be used to make outgoing calls.

- To end a call, replace the handset in its cradle.
- To receive a call, lift the handset when ringing is heard.
- Take care, if using a model with either a long handset cord or optional headset, not to allow cables to tangle or snare around the body or neck.

5.2 Last Number Redial

(15 and 18 button versions only)

Press LR to redial the last dialled number.

5.3 Recall Function

(15 and 18 button versions only)

The R button can be used to pulse a relay in a remote GAI-Tronics VoIP telephone, for example to activate a door lock release. Please see the configuration guide for full details.

5.4 Secrecy or Mute Function

(15 and 18 button versions only)

During a call, press and hold the S button to mute the microphone.

5.5 Headset Operation

The Commander 1114 can be supplied fitted with a headset option, permitting hands-free operation. Only use the approved GAI-Tronics supplied headset and headset extension cable.

To use:

1. Insert headset plug into marked connector, observing keyway.
2. To make or answer a call, turn the switch to the 'I' position.
3. To terminate the call, turn the switch to the 'O' position.
4. To remove the headset, pull the body of the connector to release the latching mechanism. Do not attempt to disconnect the headset by pulling the cable as damage may result.

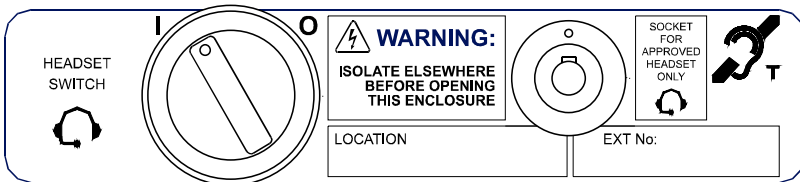
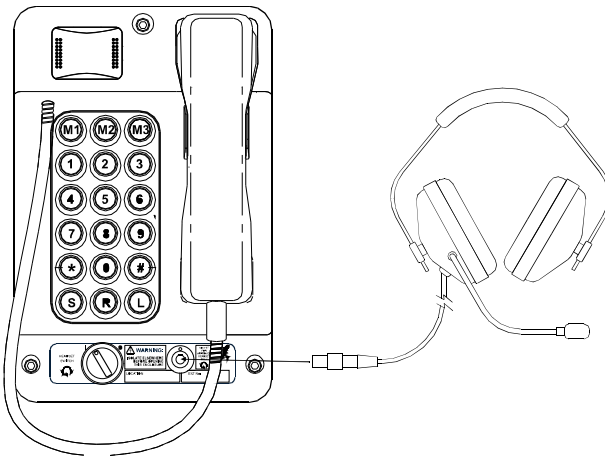

NOTE: If the handset is lifted during a call using the headset, the handset microphone will be muted. The handset can be used normally if a call is not in progress via the headset.

The headset must be used in accordance with the manufacturer's manual (supplied with headset).

6 Maintenance

The Commander 1114 is based on highly reliable integrated circuits. Under normal operation, the telephone is maintenance free.

6.1 Procedures

A programme of regular external visual inspection and cleaning is recommended, with particular attention being paid to -

On all models:

- Overall cleanliness of the telephone:
Wipe clean as necessary with a cloth dampened with clear water.
If heavily soiled, a little dishwashing liquid may be used in addition.
NOTE: high pressure hoses should not be used for cleaning.
- Security of the installation on wall, pole or post.
- Security and integrity of cable entries.
- Security of the three body screws.
- Cleanliness, integrity and condition of the handset:
Wipe clean as necessary with a cloth dampened with clear water, and disinfect the handset.
Do not allow liquid to penetrate the earpiece or mouthpiece.
- Security and condition of the handset cable.
On headset models, refer to headset manufacturer's manual for cleaning, hygiene and maintenance of headset.

6.2 Fault Finding & Field Repairs

The Commander 1114 contains no user serviceable parts and in the event of damage or failure must be replaced with a tested telephone of the correct type.

Refer to section 6.3 for a list of possible fault conditions.

6.3 Possible Operating Faults

The following operating and installation conditions could give rise to faults. During installation, or in the event of a fault, please ensure that the following do not occur:

- Water ingress
- Incorrect positioning of ribbon cable (Section 4.8)
- Damage to any internal components
- Overstressing of screws
- Insecure fixing
- Incorrect installation of glands (Section 4.4)
- Incorrect wiring or cable connections (Section 4.6)
- Improper reassembly following connection
- Additional holes drilled in casing

7 Technical Specifications

7.1 Suitability for Use

It is the responsibility of the installer or user to determine whether or not Commander 1114 is suitable for use in a given location or particular circumstances.

Please note that Commander 1114 is not certified for installation or use in hazardous areas.

7.2 Product Features

| | | |
|----------------------------|---|---|
| Power supply | Power-over-Ethernet, IEEE 802.3af , (alternative B only, ie spare pair not data pair), maximum voltage 57V or External power supply: 24-48Vdc nominal, 250mA. Limits 22-53V. A separate, isolated supply must be provided for each telephone. | |
| Hookswitch | Electronic with no external moving parts | |
| Ringer loudness | Maximum 90dBA @ 1m | |
| Handset | Suitable for inductive coupling to Hearing Aids having a `T' switch position. Tested to ETS 300-381 |  |
| Network | 10/100 BaseT Ethernet RJ45, Cat5 or Cat5e STP Static IP provisioning or DHCP | |
| Call control signalling | SIP (RFC3261 compliant) Loose routing | |
| External inputs | None | |
| External output | Output 1 - rating 5A at 250Vac, 1A at 24Vdc | |
| Codecs | G.711 A-Law G.711 μ -Law G.722 G.729 G.723.1 MP-MLQ G.723.1 ACELP Codec preference sequence DTMF in-band / out-of-band (RFC2833) Configurable comfort tones (to emulate national tones) | |
| Configuration | Embedded web server Embedded Telnet server Configuration file download Configuration file building tool (Vconf.exe) Command line interface SNTP with timezone and daylight saving Automatic updating via TFTP Password protection | |

| | |
|-------------------------------|--|
| Monitoring and reporting | Real-time over TCP/IP Syslog application or email Embedded SMTP client Automatic fault reporting Handset integrity monitoring |
| Call diversion (on auto-dial) | Configurable call lists (max 20 entries) Numbers or URIs (with comfort tones) Divert to next in list if the call fails |

7.3 Headset

For models fitted with headset socket, use only GAI-Tronics headset part number 100-02-0598-001, which is supplied fitted with the correct plug. See section 5.5 for operation.

7.3.1 Optional Headset Extension lead

The standard headset cord is approximately 820mm long and can extend to approximately 2m (dependant on safe operating conditions.)

A separate headset extension lead is available as an optional extra (part No. 610-35-2036-001). This will allow the operator to use the headset over 6 metres away from the telephone unit. Note: Refer to section 1 for hazard warnings regarding long corded Headsets & handsets.

7.4 Physical Characteristics

| | |
|------------------|---|
| Casing material | Carbon loaded glass filled polyester body - rugged and corrosion free |
| Handset Material | Cycoloy (2800) with stainless steel or polyester curled cord. |
| Weight | 3.7kg (8.4lbs). |
| Dimensions | 190W x 292H x 140D mm overall (7.5 x 11.5 x 5.5 in) Standard handset cord lengths: Curled cord: 320mm extending to 1000mm (13-39in) Armoured steel cord: 755mm (29.7in) |

7.5 Environmental Considerations

WARNING: The telephone must only be **stored and operated** within the temperature ranges stated below. Subjecting the telephone to temperatures outside these ranges will shorten the life of its electronic components.

| | |
|---|--|
| Storage temperature range | -20°C to +50°C (-4 °F to 122 °F) |
| Operating temperature range | -20°C to +50°C (-4 °F to 122 °F) |
| Maximum relative humidity | 95% non condensing |
| Telephone enclosure IP Rating: | IP66 (curly cord variants) IP54 (steel cord variants) <i>(NB the handset is excluded from this rating)</i> |
| High pressure hoses should not be used on this product. | |

7.6 Related Standards and Regulations

Commander 1114 is fully compliant with the following:

7.6.1 EMC Testing to:

EN55022:2006 (Class B) – Information technology equipment. Radio disturbance characteristics.

EN55024:1998 – Information technology equipment. Immunity characteristics.

7.6.2 Safety compliance to:

EN60079-0:2006 - Electrical apparatus for explosive gas atmospheres Part 0: General requirements.

EN60079-0:2007 - Electrical apparatus for explosive gas atmospheres Part 0: General requirements.

EN60079-7:2007 - Electrical apparatus for explosive gas atmospheres Part 7: Increased safety 'e'.

EN60079-11:2007 - Electrical apparatus for explosive gas atmospheres Part 11: Protection by intrinsic safety 'i'.

EN60079-18:2007 - Electrical apparatus for explosive gas atmospheres Part 18: Construction, test and marking of type of protection encapsulation 'm' electrical apparatus.

7.6.3 European Directives:

1999/5/EC – European Radio Equipment & Telecommunications Terminal Equipment Directive.



This mark indicates compliance with the following directives for this product;
R&TTE Directive 1999/5/EC



Suitable for inductively coupling to Hearing Aids having a `T' switch position. Use of this facility for any other purpose than that for which it was intended may cause degradation in quality of a connection.

Tested to ETS 300-381



The GAI-Tronics Quality Management System has been approved by LRQA to ISO9001-2000. Certificate No. 861888

7.7 Recycling Information

The symbol shown here and on the product means that the product is classed as Electrical or Electronic Equipment and should not be disposed with other household or commercial waste at the end of its working life.



The Waste of Electrical and Electronic Equipment (WEEE) Directive has been put in place to recycle products using best available recovery and recycling techniques to minimise the impact on the environment, treat any hazardous substances and avoid the increasing landfill.

Business users should contact their suppliers and check the terms and conditions of the purchase contract and ensure that this product is not mixed with other commercial waste for disposal.

8 CE Declaration

A copy of the current CE Declaration of Conformity is available from our website. www.gai-tronics.org/support/certificates-approvals/

9 Licensing Notices

The firmware in GAI-Tronics VoIP products contains modules subject to licensing and copyright as follows:

| Module | License |
|--------------|---------------------------------|
| u-boot | GPL V2 |
| Linux kernel | GPL V2 |
| Busybox | GPL V2 |
| Opal/PWLib | Mozilla Public License V1.1 |
| Modutils | GPL V2 |
| MTD | GPL V2 |
| NTP | David L. Mills Copyright Notice |

These licence and copyright notices are available in full from our website at www.gai-tronics.org/support/voip-support/

GAI-TRONICS

A division of Hubbell Ltd.

Brunel Drive

Stretton Park

Burton upon Trent

Staffordshire

DE13 0BZ

www.gai-tronics.co.uk

Tel: +44 (0)1283 500 500

Fax: +44 (0)1283 500 400

If you have any difficulties, please call.

The policy of GAI-Tronics is one of continuous improvement,
therefore the Company reserves the right to change
specifications without notice.

The contents of this publication are confidential, are the property of GAI-Tronics, and may not
be reproduced, wholly or in part, without their written permission.

E&OE.